

NINJA DZ071 Dual Zone Flex Basket Air Fryer



NINJA DZ071 Dual Zone Flex Basket Air Fryer Instruction Manual

[Home](#) » [Ninja](#) » NINJA DZ071 Dual Zone Flex Basket Air Fryer Instruction Manual 

Contents

- [1 NINJA DZ071 Dual Zone Flex Basket Air Fryer](#)
- [2 Product Information](#)
- [3 FAQs](#)
- [4 TECHNICAL SPECIFICATIONS](#)
- [5 IMPORTANT SAFETY INSTRUCTIONS](#)
- [6 PARTS](#)
- [7 FUNCTIONS](#)
- [8 BEFORE FIRST USE](#)
- [9 TROUBLESHOOTING GUIDE](#)
- [10 WARRANTY](#)
- [11 Documents / Resources](#)
 - [11.1 References](#)

NINJA

NINJA DZ071 Dual Zone Flex Basket Air Fryer



Product Information

• Specifications:

- **Voltage:** 120V~, 60Hz
- **Watts:** 1690W
 - This product is manufactured by SharkNinja Operating LLC and is designed for household use only.
 - It is important to read all instructions provided in the user manual before using the product.
 - The model and serial numbers can be found on the QR code label on the back of the unit near the power cord.

• Important Safety Instructions:

- It is crucial to follow all safety instructions provided in the manual to prevent any hazards that could cause personal injury, property damage, or even death. Some key safety instructions include avoiding contact with hot surfaces, keeping the appliance out of reach of children, and providing adequate space for air circulation during use.

• Important Safeguards:

- Ensure that the appliance is placed on a level, clean, and dry surface during use.
- Do not move the appliance while it is in operation.
- Avoid placing the appliance near the edge of a worktop during use.
- Only use accessories recommended or sold by SharkNinja to prevent fire, electric shock, or injuries.

• Product Usage Instructions:

- **Supervision:** This appliance can be used by individuals with reduced capabilities if they have received proper supervision or instruction on safe usage.
- **Child Safety:** Keep the appliance and its cord out of reach of children. Do not allow children to operate the appliance without supervision.

- **Air Circulation:** Provide at least 6 inches of space above and around the appliance for proper air circulation during operation.
- **Cleaning and Maintenance:** Regularly inspect the appliance and power cord for any damage. Do not use the appliance if there are any signs of damage.

FAQs

- **Q: Where can I find the model and serial numbers of the product?**
 - **A:** The model and serial numbers can be found on the QR code label located on the back of the unit near the power cord.
- **Q: Can children operate this appliance?**
 - **A:** Children should not operate this appliance without proper supervision. Keep the appliance out of reach of children.

RECORD THIS INFORMATION

- **Model Number:** _____
- **Serial Number:** _____
- **Date of Purchase:** _____ (Keep receipt)
- **Store of Purchase:** _____





TIP: You can find the model and serial numbers on the QR code label on the back of the unit by the power cord.

TECHNICAL SPECIFICATIONS

- **Voltage:** 120V~, 60Hz
- **Watts:** 1690W

IMPORTANT SAFETY INSTRUCTIONS

HOUSEHOLD USE ONLY. READ ALL INSTRUCTIONS BEFORE USE.

	Read and review Instructions to understand operation and use of product.
	Indicates the presence of a hazard that can cause personal injury, death or substantial property damage if the warning included with this symbol is ignored.
	Avoid contact with hot surface. Always use hand protection to avoid burns.
	For indoor use only.

WARNING Failure to follow these instructions could result in electric shock, fire, or burn hazard which could cause property damage, personal injury, or death. When using electrical appliances, basic safety precautions should always be followed, including the following:

1. This appliance can be used by persons with reduced physical, sensory or mental capabilities or lack of experience and knowledge if they have been given supervision or instruction concerning the use of the appliance in a safe way and understand the hazards involved.

2. Keep the appliance and its cord out of reach of children. DO NOT allow the appliance to be used by children.
Close supervision is necessary when used near children
3. Children should not play with the appliance.
4. NEVER use the electrical socket below the counter.
5. NEVER connect this appliance to an external timer switch or a separate remote-control system.
6. When using this appliance, provide at least 6 inches (15.25 cm) of space above and on all sides for air circulation.
7. To protect against electrical shock DO NOT immerse cord, plugs, or main unit housing in water or other liquid.
Cook only in the basket provided.
8. Regularly inspect the appliance and power cord. DO NOT use the appliance if there is damage to the power cord or plug. If the appliance malfunctions or has been damaged in any way, immediately stop use and call Customer Service.
9. DO NOT place the appliance on or near a gas or electric stovetop, or in a heated oven.
10. DO NOT use an extension cord. A short power-supply cord is used to reduce the risk of children grabbing the cord or becoming entangled and to reduce the risk of people tripping over a longer cord.
11. ALWAYS ensure the appliance is properly assembled before use.
12. DO NOT cover the air intake vent or air outlet while the unit is operating. Doing so will prevent even cooking and may damage the unit or cause it to overheat.
13. Before placing the removable basket into the main unit, ensure the basket and unit are clean and dry by wiping it with a soft cloth.
14. This appliance is for household use only. DO NOT use this appliance for anything other than its intended use. DO NOT use in moving vehicles or boats. DO NOT use outdoors. Misuse may cause injury.
15. Intended for worktop use only. Ensure the surface is level, clean and dry. DO NOT move the appliance when in use.
16. DO NOT place the appliance near the edge of a worktop during operation.
17. DO NOT use accessory attachments not recommended or sold by SharkNinja. Do not place accessories in a microwave, toaster oven, convection oven, or conventional oven or on a ceramic cooktop, electric coil, gas burner range or outdoor grill. The use of accessory attachments not recommended by SharkNinja may cause fire, electric shock or injuries.
18. ALWAYS ensure the basket is properly closed before operating.
19. DO NOT use the appliance without the removable basket installed.
20. DO NOT use this appliance for deep-frying.
21. DO NOT place appliances on hot surfaces, near a hot gas or electric burner, in a heated oven, or on a stovetop.
22. Prevent food contact with heating elements. DO NOT overfill when cooking. Overfilling may cause personal injury or property damage or affect the safe use of the appliance.
23. DO NOT place items on top of unit at any time.
24. Socket voltages can vary, affecting the performance of your product. To prevent possible illness, use a thermometer to check that your food is cooked to the temperatures recommended.
25. Should the unit emit black smoke, unplug it immediately. Wait for smoking to stop before removing any cooking accessories.
26. DO NOT touch hot surfaces. Appliance surfaces are hot during and after operation. To prevent burns or personal injury, ALWAYS use protective hot pads or insulated oven mitts and use available handles.
27. Extreme caution must be used when the appliance contains hot food. Improper use may result in personal

injury.

28. This appliance has a polarized plug (one blade is wider than the other). To reduce the risk of electric shock, this plug is intended to fit into a polarized outlet only one way. If the plug does not fit fully into the outlet, reverse the plug. If it still does not fit, contact a qualified electrician. DO NOT attempt to modify the plug in any way.
29. Spilled food can cause serious burns. Keep appliances and cords away from children. DO NOT let the cord hang over the edges of tables or counters or touch hot surfaces.
30. The basket and crisper plate become extremely hot during the cooking process. Avoid physical contact while removing the basket or plate from the appliance. ALWAYS place a basket or plate on a heat-resistant surface after removing it. DO NOT touch accessories during or immediately after cooking.
31. Cleaning and user maintenance should not be carried out by children.
32. To disconnect, press the power button to turn off the unit, then unplug from the socket when not in use and before cleaning. Allow to cool before cleaning, disassembly, putting in or taking off parts and storage.
33. DO NOT clean with metal scouring pads. Pieces can break off the pad and touch electrical parts, creating the risk of electric shock.
34. Please refer to the Cleaning & Maintenance section for regular maintenance of the appliance.

PARTS

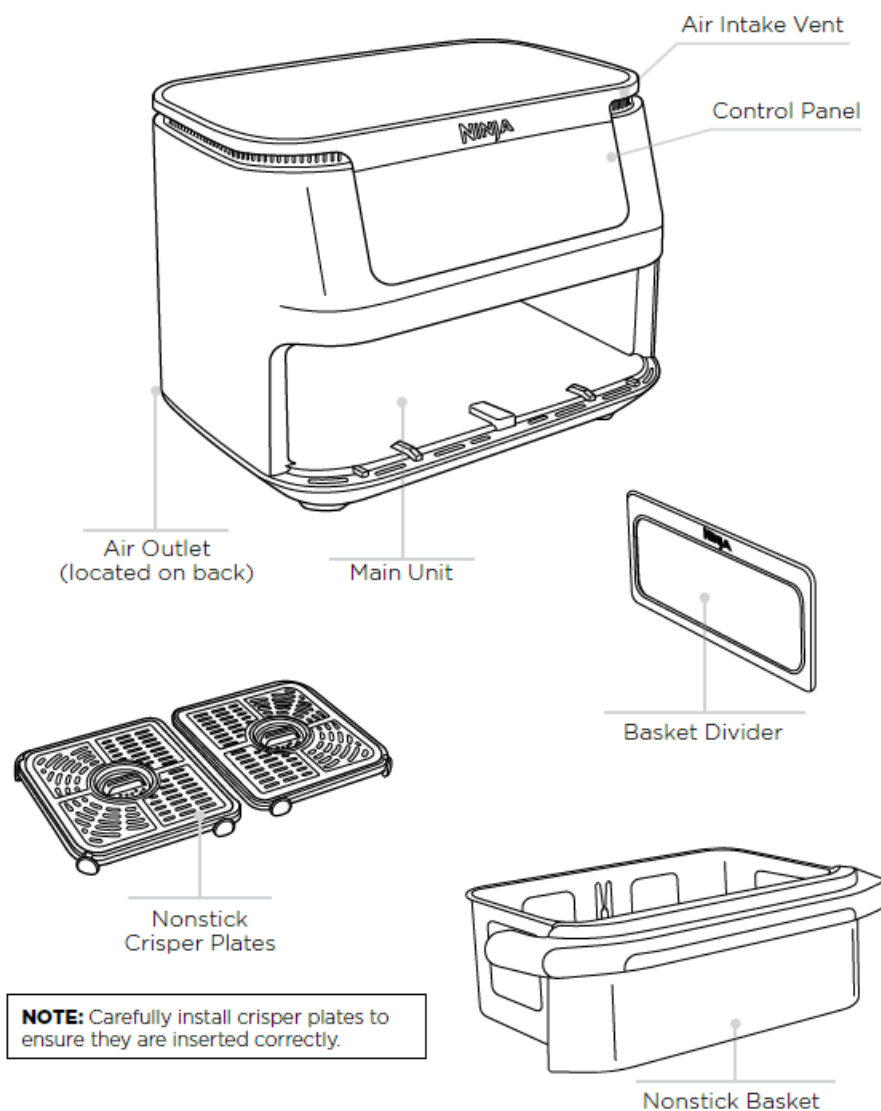

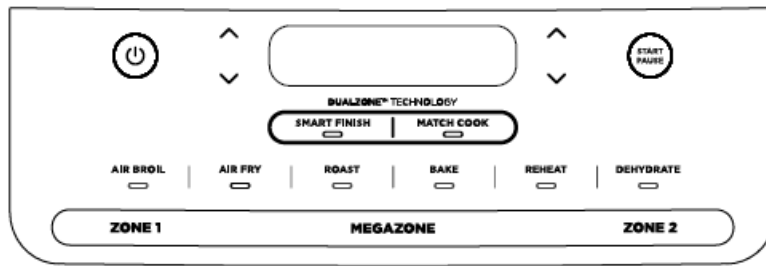

When setting time, the digital display shows HH:MM.

FUNCTIONS

NOTE: Not all functions are included on all models.

- **AIR BROIL:** Add the crispy finishing touch to meals, or melt toppings to create the perfect finish.
- **AIR FRY:** Use this function to give your food crispiness and crunch with little to no oil.
- **ROAST:** Roast meats to tenderize and more.
- **BAKE:** Create decadent baked treats and desserts.
- **REHEAT:** Warm your leftovers, with a crispy result.
- **DEHYDRATE:** Dehydrate meats, fruits, and vegetables for healthy snacks.

OPERATING BUTTONS

1. Allows you to control the left-hand zone.
2. Allows you to control the right-hand zone.
 - **TEMP arrows:** Use the left-hand up and down arrows to adjust the temperature before or during cooking.
 - **TIME arrows:** Use the right-hand up and down arrows to adjust the time before or during cooking.
 - **SMART FINISH button:** Automatically syncs the cook times to ensure both zones finish at the same time, even if there are different cook times.
 - **MATCH COOK button:** Automatically matches Zone 2 settings to those of Zone 1 to cook a larger amount of the same food, or cook similar foods using the same function, temperature, and time.
 - **MEGAZONE button:** Remove the divider to cook in one unified high-capacity zone.
 - **POWER BUTTON:** The  button turns the unit on and off and stops all cooking functions.
 - **Standby Mode:** After 10 minutes of no interaction with the control panel, the unit will enter standby mode. The Power button will be dimly lit.
 - **Hold Mode:** Hold will appear on the display while in Smart Finish™ mode. One zone will be cooking, while the other zone will be held until the times sync.
 - **START/PAUSE BUTTON:** Start or pause cooking.

BEFORE FIRST USE

1. Remove and discard any packaging material, promotional labels, and tape from the unit.
2. Remove all accessories from the package and read this manual carefully. Please pay particular attention to operational instructions, warnings, and important safeguards to avoid any injury or property damage.
3. Wash the basket, divider, and crisper plates in hot, soapy water, then rinse and dry thoroughly. The basket,

divider, and crisper plates are the ONLY dishwasher-safe parts. NEVER clean the main unit in the dishwasher.

COOKING IN YOUR FLEXBASKET™ AIR FRYER REFERENCE QUICK START GUIDE FOR RECIPES AND COOKING CHARTS

COOKING WITH DUALZONE™ TECHNOLOGY

- DualZone Technology utilizes two cooking zones to increase versatility.
- The Smart Finish feature ensures that, regardless of different cook settings, both zones will finish cooking at the same time.
- For detailed instructions on using each function, see pages 8–15.

NOTE: There is no preheat needed. Once you have made your selections, press the START/PAUSE button to begin cooking.

SMART FINISH™

To finish cooking at the same time when foods have different cooking times, temps, or functions:

1. Insert divider in the basket, then insert crisper plates. Place ingredients in each zone, then insert basket in the unit.
2. Zone 1 will remain illuminated. Select the desired cook function. Use the TEMP arrows to set the temperature, and use the TIME arrows to set the time.



3. Select Zone 2, then select the desired cook function (Air Broil can be used in only one zone when using Smart Finish). Use the TEMP arrows to set the temperature, and use the TIME arrows to set the time.

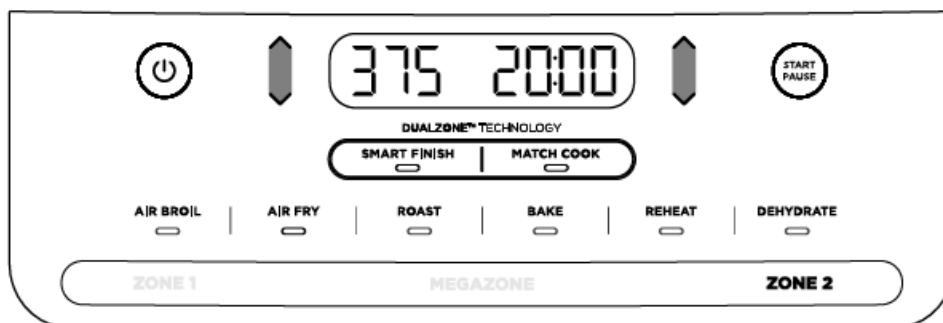

- **NOTE:** Air Brazil can be used in only one zone.
 - **NOTE:** You can select a different function for Zone 2.
4. Press SMART FINISH, then press START/ PAUSE to begin cooking in the zone for the longest time. The other zone will display Hold. The unit will beep and activate the second zone when both zones have the same cook time remaining.



- **NOTE:** We recommend shaking food during cooking. To keep the time at a synchronized finish, press START/ PAUSE to pause both zones. To pause a single zone during dual zone cooking, refer to page 10.

5. When cooking is complete, the unit will beep and “End” will appear on the display.

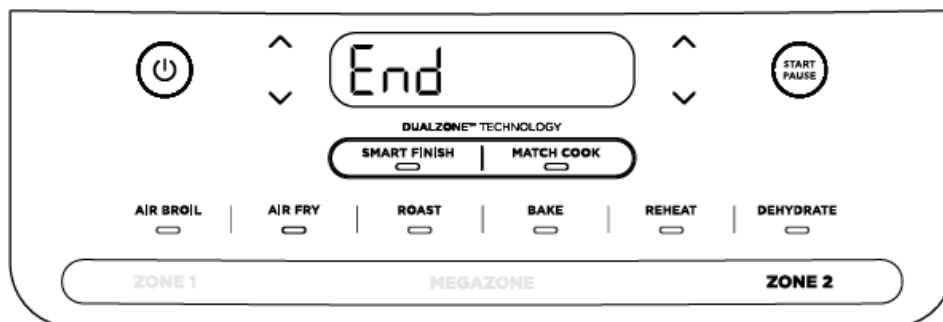

6. Remove ingredients by dumping them out or using silicone-tipped tongs/utensils. DO NOT place the basket on top of unit.

- **NOTE:** If you decide the food in one of the zones is done cooking before the cooking time is up, you can STOP A ZONE. Select that zone, then press START/PAUSE to pause the zone or set the time to zero. See page 12 for further instructions.

MATCH COOK™

To cook a larger amount of the same food, or cook similar foods using the same function, temperature, and time:

1. Place ingredients in the basket, then insert the basket into the unit.
2. Zone 1 will remain illuminated. Select the desired cook function (Air Broil is not available for use in either zone when using Match Cook). Use the TEMP arrows to set the temperature, and use the TIME arrows to set the time. Make sure to insert the removable divider before placing your ingredients.



3. Press the MATCH COOK button to copy the Zone 1 settings to Zone 2. Then press START/PAUSE to begin

cooking in both zones.



- **NOTE:** Air Broil cannot be used in Match Cook mode.
- **NOTE:** We recommend shaking food during cooking. To keep the time at a synchronized finish, press START/ PAUSE to pause both zones. To pause a single zone during dual zone cooking, refer to page 10.

4. "End" will appear on both screens when cooking ends at the same time.

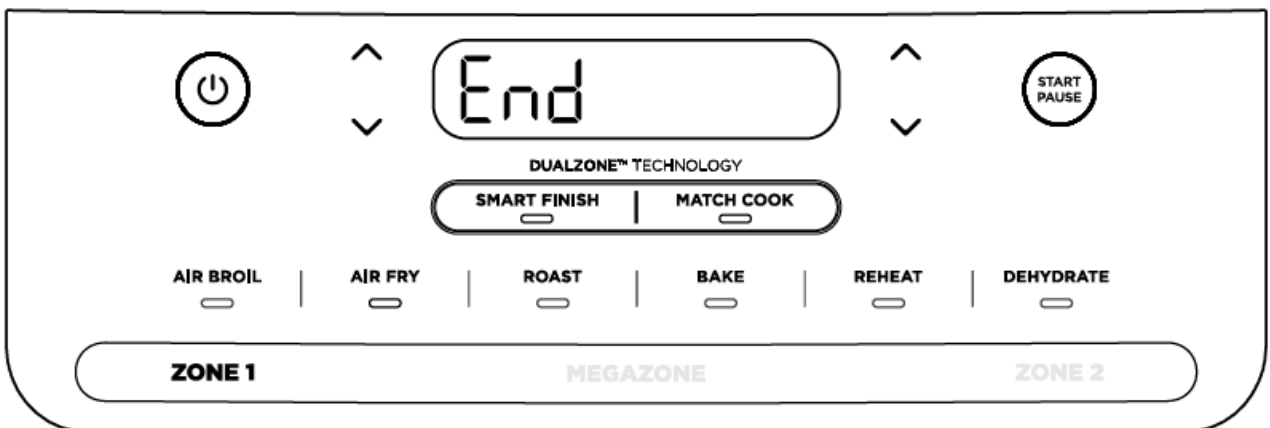

5. Remove ingredients by dumping them out or using silicone-tipped tongs/utensils.

COOKING WITH TWO ZONES

When Smart Finish™ or Match Cook are not selected, technology is integrated into the design to automatically optimize the distribution of power when using two zones with different cook times. This means the food in the zone with the longer cooking time may finish cooking before the set time ends. Check food frequently to avoid overcooking.

1. Select Zone 1, then select the desired cook function. Use the TEMP arrows to set the temperature.



2. Use the TIME arrows to set the time.



3. Repeat steps 1 and 2 for Zone 2.



4. Press START/PAUSE to begin cooking in both zones.



5. When cooking is complete in the zone with the shorter cook time, the power will then shift to help optimize cook time in the remaining zone.

6. Continue to monitor food, as it may finish cooking before the set cooking time ends.

7. Remove ingredients by dumping them out or using silicone-tipped tongs/utensils.

COOKING IN A SINGLE ZONE

- For instructions on using both zones at the same time, see pages 6–7.
- To turn on the unit, plug the power cord into a wall outlet, then press the power  button.

Air Broil (Not available on all models.)

NOTE: Air Brazil cannot be used in both zones at the same time.

1. Insert the divider in the basket, then insert both crisper plates (unless otherwise instructed in the recipe). Place ingredients in one zone, then insert the basket in the unit.

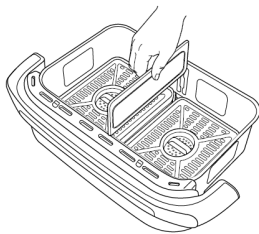

2. The unit will default to Zone 1 (to use Zone 2 instead, select Zone 2). Select AIR BROIL.

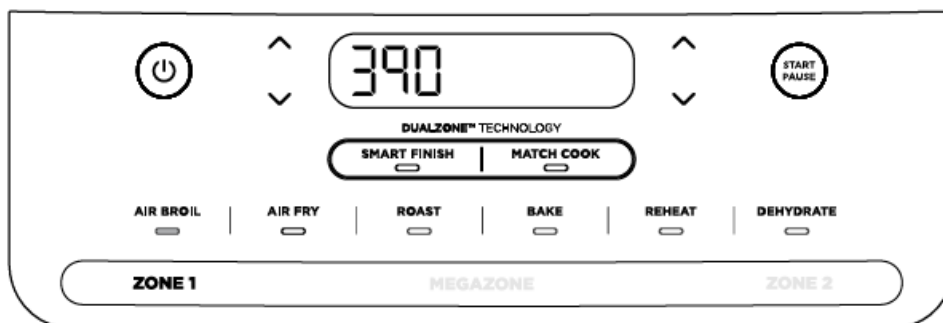

3. Use the TEMP arrows to set the desired temperature.

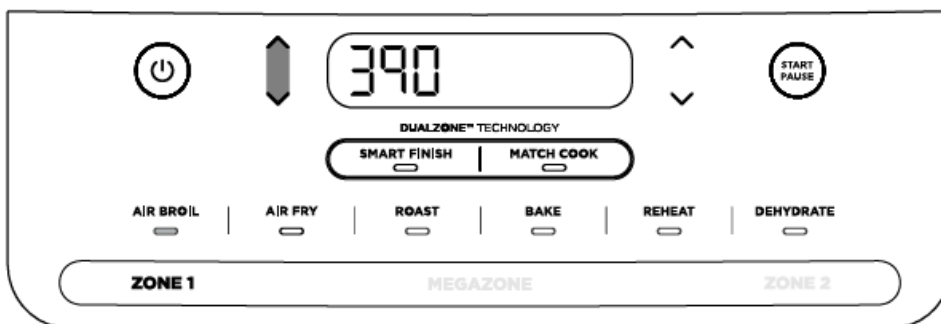

4. Use the TIME arrows to set the time in 1-minute increments up to 30 minutes. Press START/PAUSE to begin cooking.

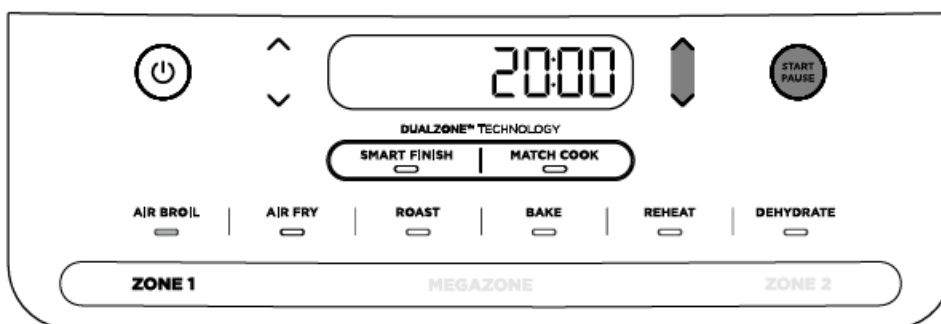

5. When cooking is complete, the unit will beep and "End" will appear on the display.

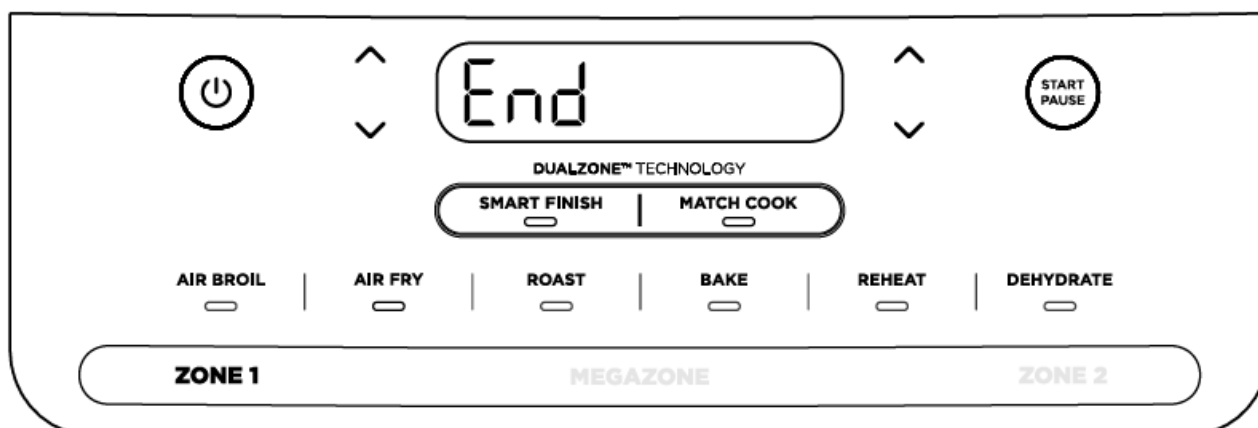

6. Remove ingredients by dumping them out or using silicone-tipped tongs/ utensils.

Air Fry

1. Insert the divider in the basket, then insert both crisper plates (unless otherwise instructed in the recipe). Place ingredients in one zone, then insert the basket in the unit.

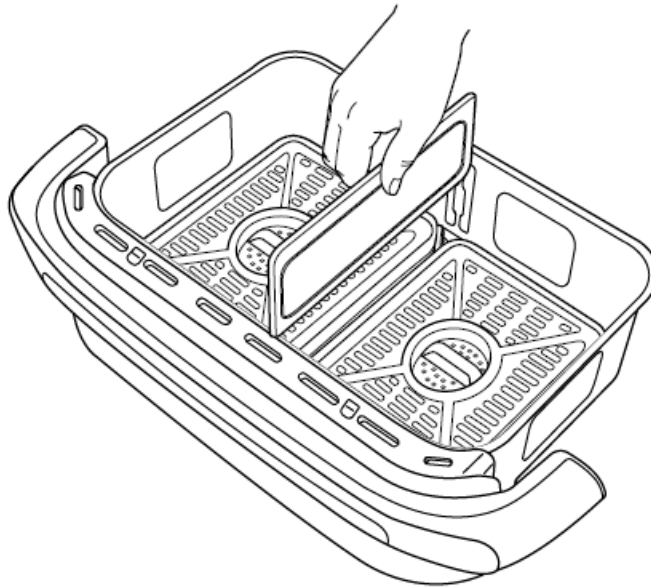

2. The unit will default to Zone 1 (to use Zone 2 instead, select Zone 2). Select AIR FRY.



3. Use the TEMP arrows to set the desired temperature.



4. Use the TIME arrows to set the time in 1-minute increments up to 1 hour. Press START/PAUSE to begin cooking.

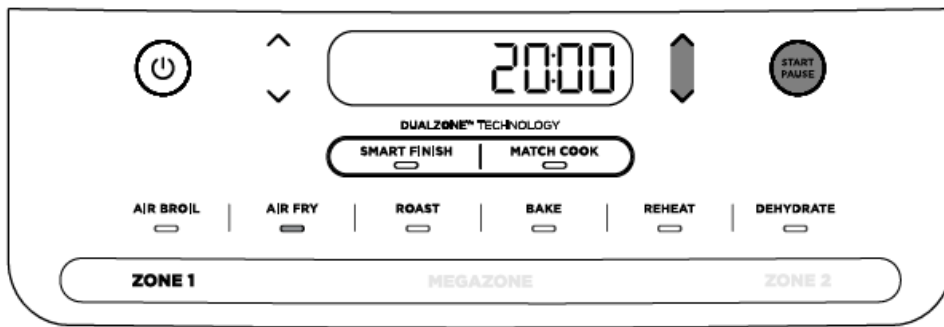

- **NOTE:** During cooking, you can remove the basket and shake or toss ingredients for evening crisping. If you would like to pause during this time, press the zone number, then press START/PAUSE. If using a single zone, press START/PAUSE.

5. When cooking is complete, the unit will beep and “End” will appear on the display.

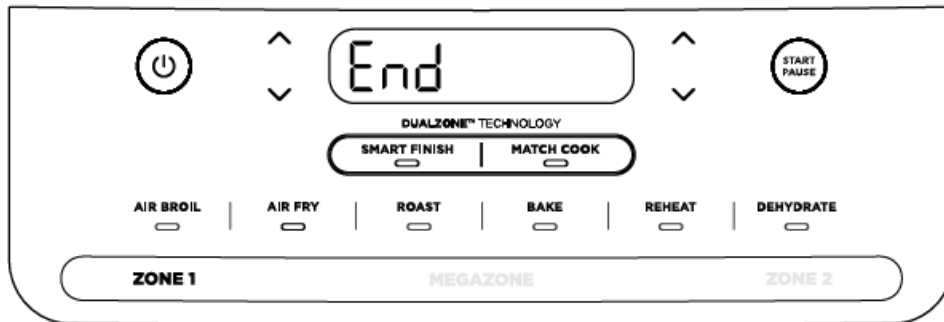

6. Remove ingredients by dumping them out or using silicone-tipped tongs/utensils.

Roast

1. Insert the divider in the basket, then insert both crisper plates (unless otherwise instructed in the recipe). Place ingredients in one zone, then insert the basket in the unit.

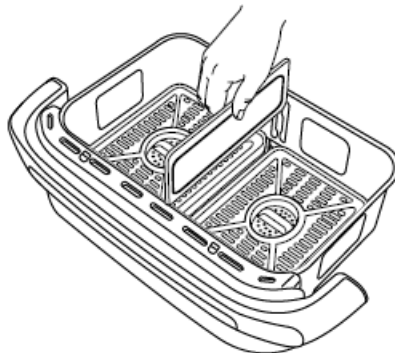

2. The unit will default to Zone 1 (to use Zone 2 instead, select Zone 2). Select ROAST.



3. Use the TEMP arrows to set the desired temperature.



4. Use the TIME arrows to set the time in 1-minute increments up to 1 hour and in 5-minute increments from 1 to 4 hours. Press START/PAUSE to begin cooking.

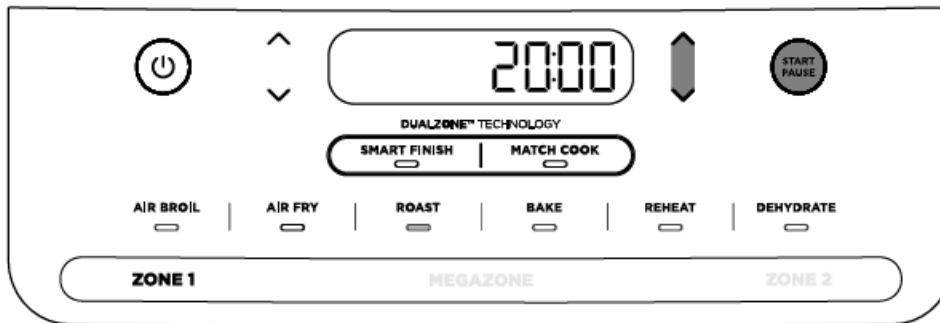

5. When cooking is complete, the unit will beep and “End” will appear on the display.

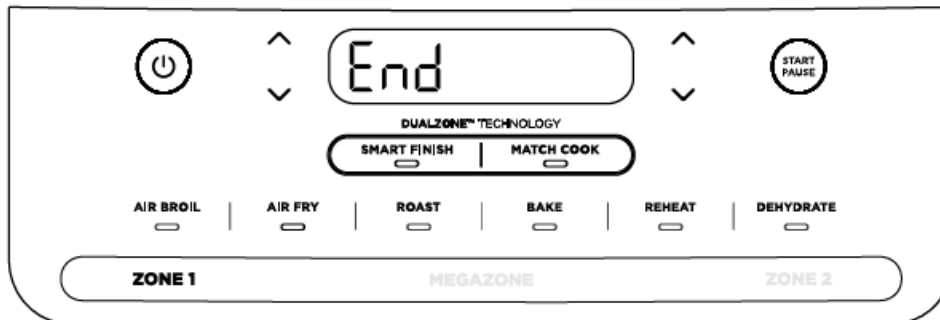

6. Remove ingredients by dumping them out or using silicone-tipped tongs/utensils.

Bake (Not available on all models.)

1. Insert divider in the basket, then insert both crisper plates (unless otherwise instructed in recipe). Place ingredients in one zone, then insert basket in the unit.

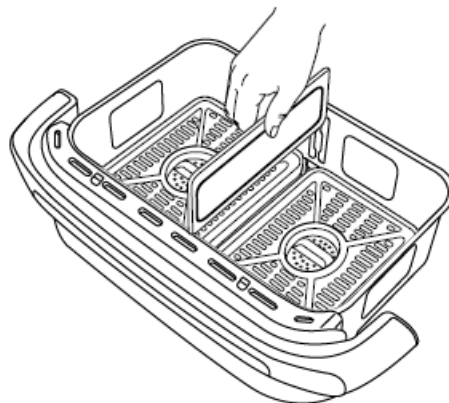

2. The unit will default to Zone 1 (to use Zone 2 instead, select Zone 2). Select BAKE.

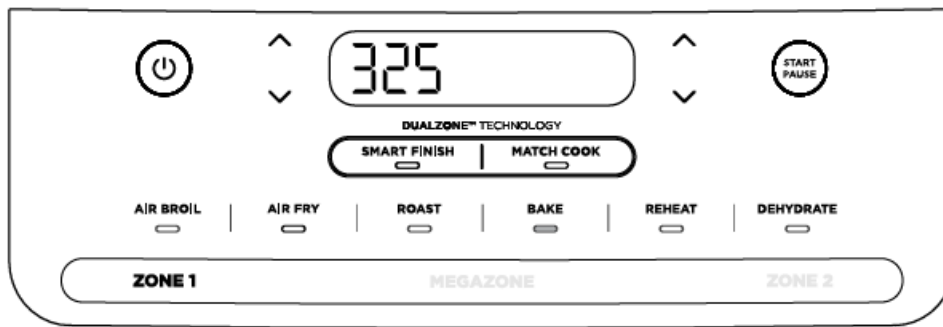

- **NOTE:** To convert recipes from a traditional oven, reduce the temperature by 25°F.

3. Use the TEMP arrows to set the desired temperature.



4. Use the TIME arrows to set the time in 1-minute increments up to 1 hour and 5-minute increments from 1 to 4 hours. Press START/PAUSE to begin cooking.

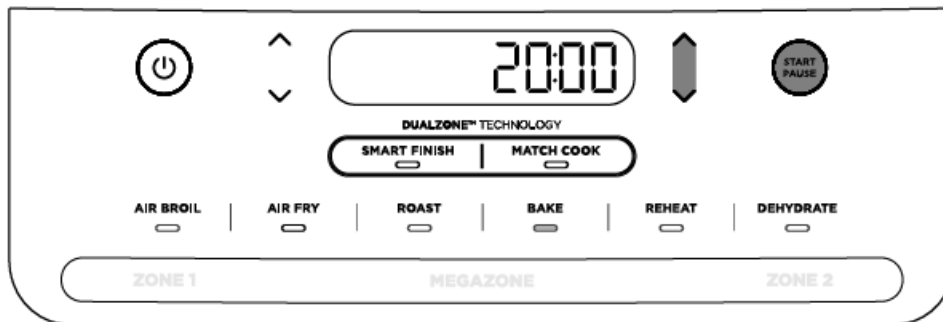

5. When cooking is complete, the unit will beep and “End” will appear on the display.

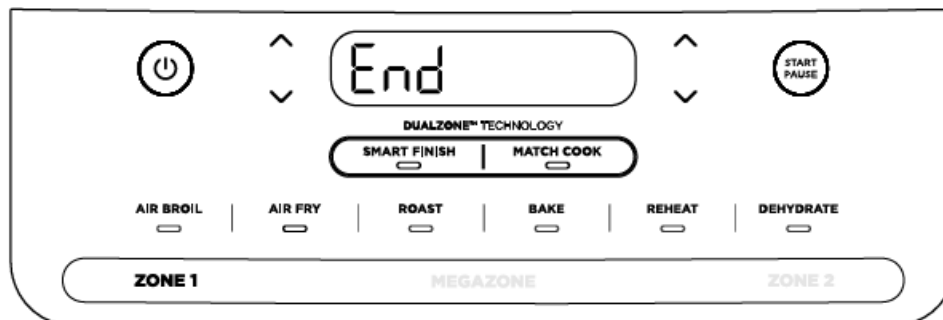

6. Remove ingredients by dumping them out or using silicone-tipped tongs/utensils.

Reheat

1. Insert divider in the basket, then insert both crisper plates (unless otherwise instructed in recipe). Place ingredients in one zone, then insert basket in the unit.

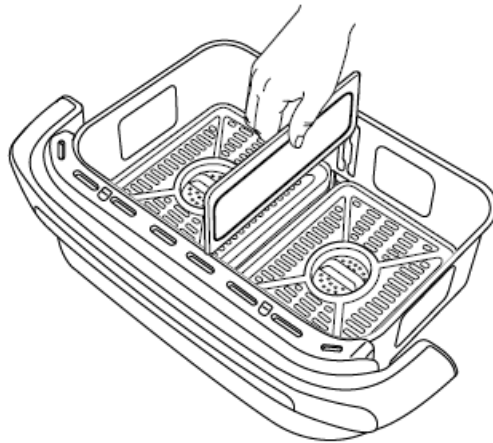

2. The unit will default to Zone 1 (to use Zone 2 instead, select Zone 2). Select REHEAT.

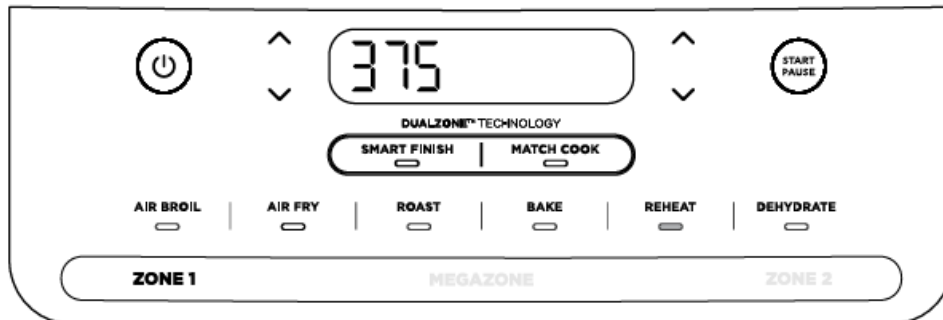

3. Use the TEMP arrows to set the desired temperature.

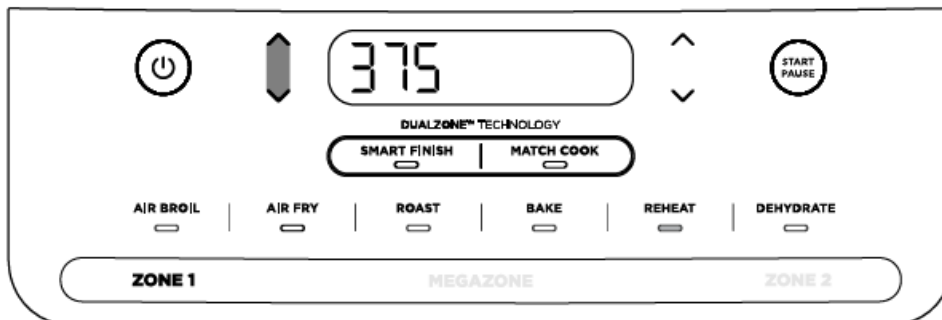

4. Use the TIME arrows to set the time in 1-minute increments up to 1 hour. Press START/PAUSE to begin reheating.

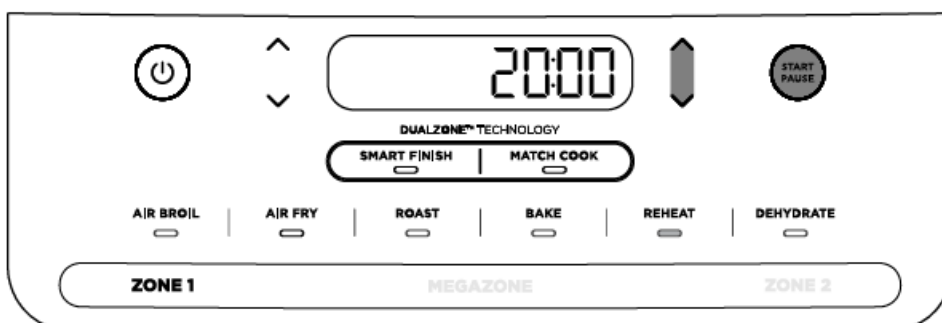

5. When reheating is complete, the unit will beep and “End” will appear on the display.

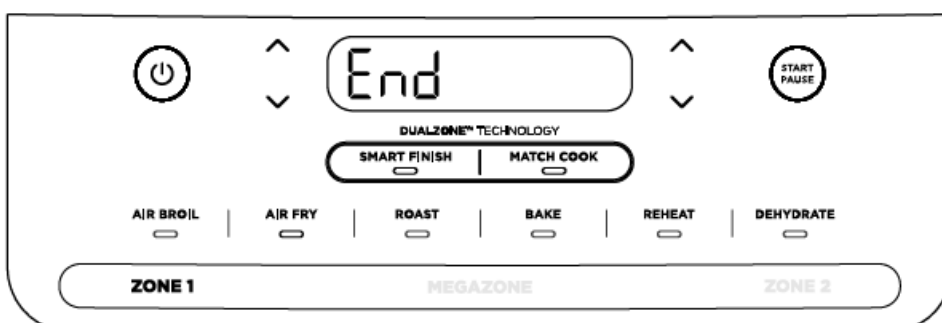

6. Remove ingredients by dumping them out or using silicone-tipped tongs/utensils.

Dehydrate

1. Insert divider in the basket.
2. Place a single layer of ingredients in the basket. Then insert a crisper plate in the basket on top of the ingredients, and place another layer of ingredients on the crisper plate.
3. The unit will default to Zone 1 (to use Zone 2 instead, select Zone 2). Select DEHYDRATE.
4. Use the TEMP arrows to set the desired temperature.

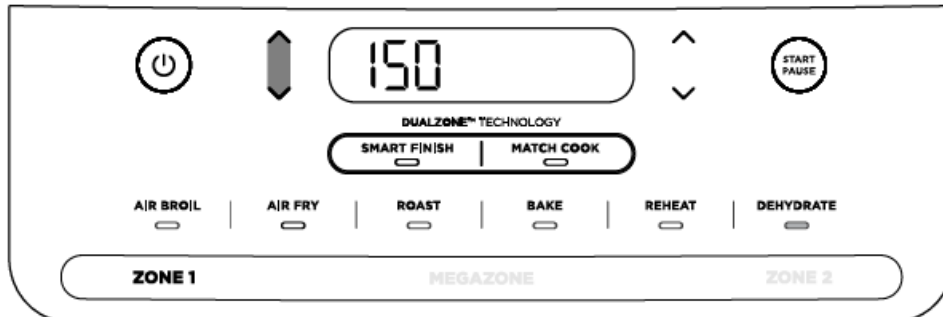

5. Use the TIME arrows to set the time in 15-minute increments from 1 to 12 hours. Press START/PAUSE to begin dehydrating.

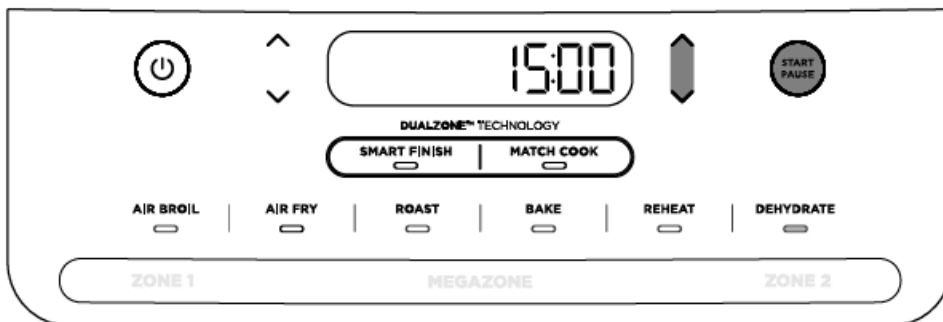

6. When cooking is complete, the unit will beep and “End” will appear on the display.

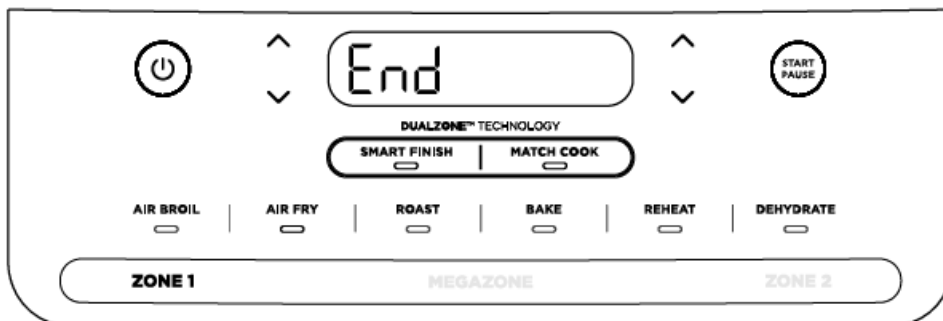

7. Remove ingredients by dumping them out or using silicone-tipped tongs/utensils.

PAUSING BOTH ZONES AT THE SAME TIME

1. To pause cooking in Smart Finish™ mode or when dual zone cooking, press START/PAUSE.

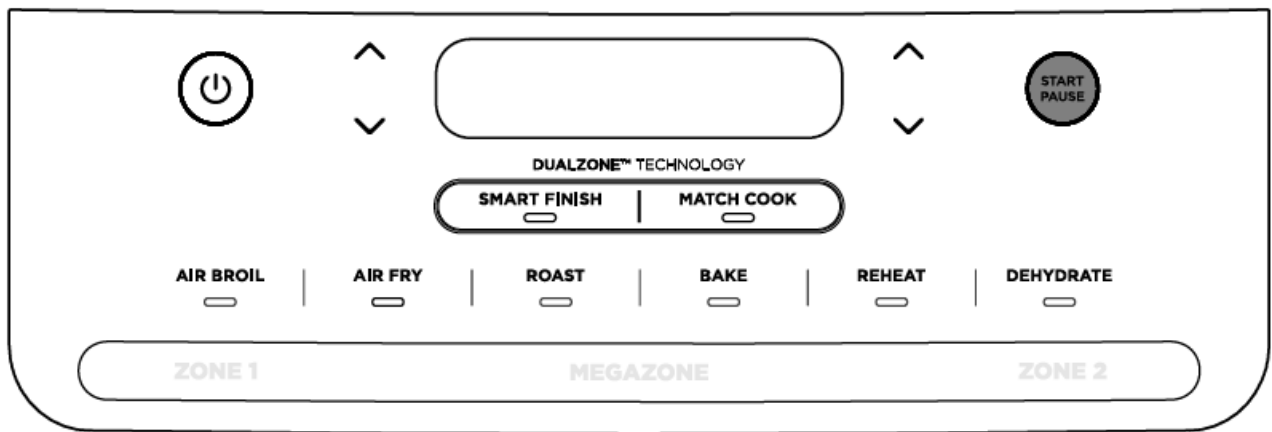

2. To resume cooking, press START/PAUSE again.

PAUSING A SINGLE ZONE DURING DUAL-ZONE COOKING

1. To pause cooking in a single zone while dual zone cooking, select the zone you want to pause, then press START/PAUSE.

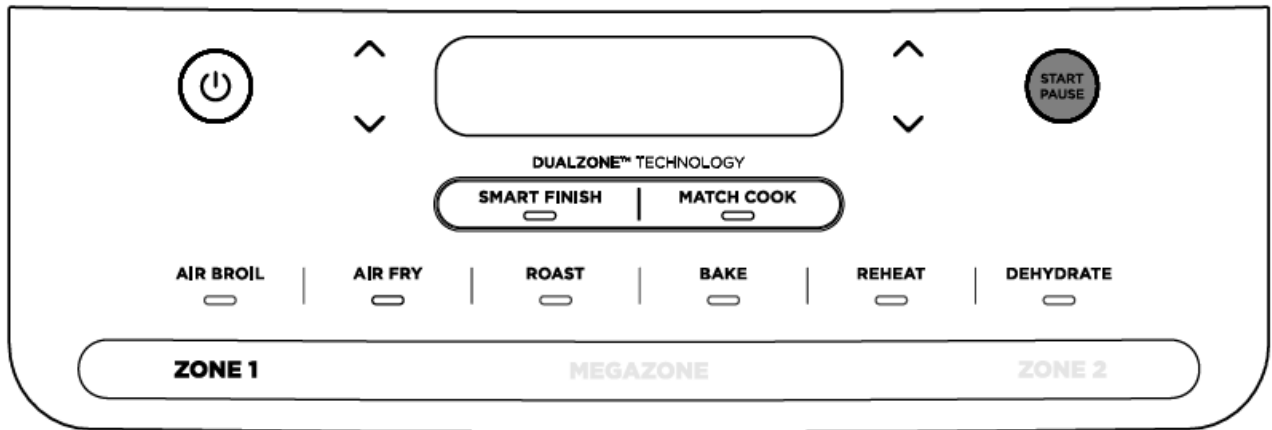

2. To resume cooking, press START/PAUSE again.

ENDING THE COOK TIME IN ONE ZONE (WHILE USING BOTH ZONES)

1. Select the zone you would like to stop.

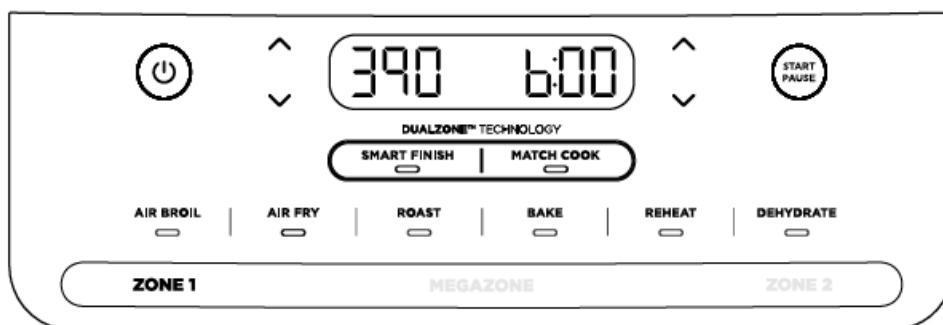

2. Then press the down TIME arrow to set the time to zero. Once you have set the time to zero, press START/PAUSE.

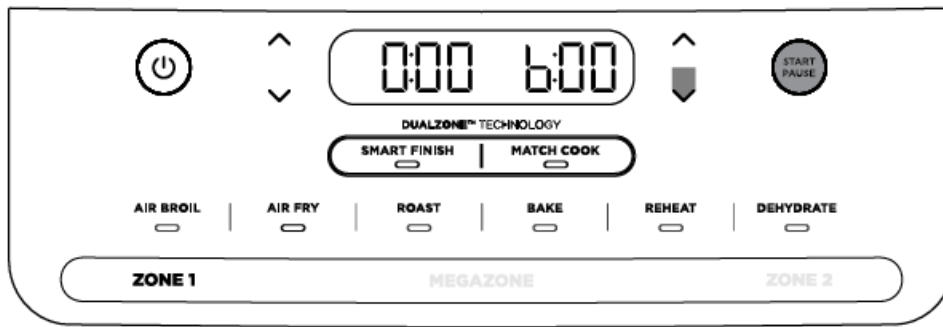

3. The time in that zone is then cancelled, and “End” will appear on the display. Cooking will continue in the other zone.

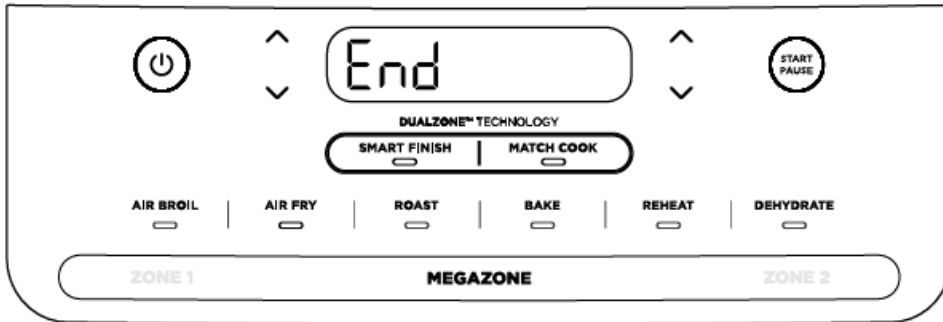

COOKING IN THE MEGAZONE™

- For instructions on using both zones at the same time, see pages 6–7.
- To turn on the unit, plug the power cord into a wall outlet, then press the power  button.

Air Broil (Not available on all models.)

1. Remove the divider from the basket, then insert both crisper plates in the basket. Place ingredients in the basket, then insert the basket into the unit.

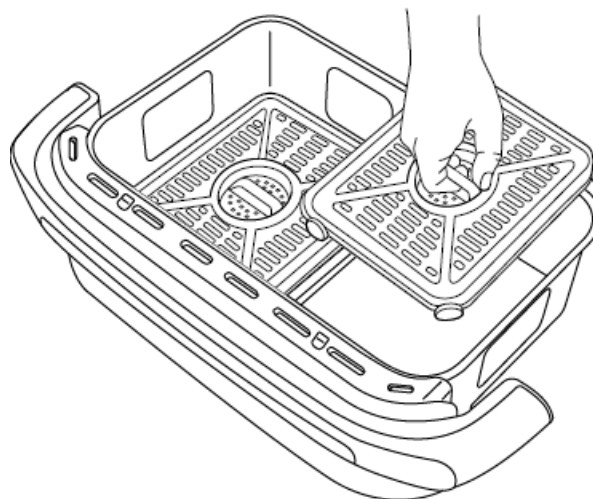

2. The unit will default to Zone 1. Select MEGAZONE, then select AIR BROIL.

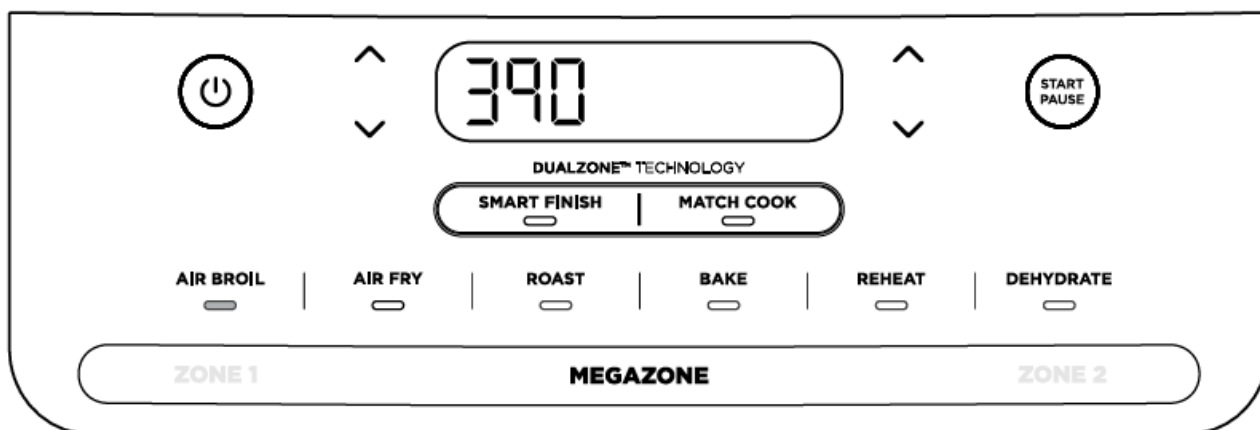

3. Use the TEMP arrows to set the desired temperature.



4. Use the TIME arrows to set the time in 1-minute increments up to 30 minutes. Press START/PAUSE to begin cooking.



5. When cooking is complete, the unit will beep and “End” will appear on the display.

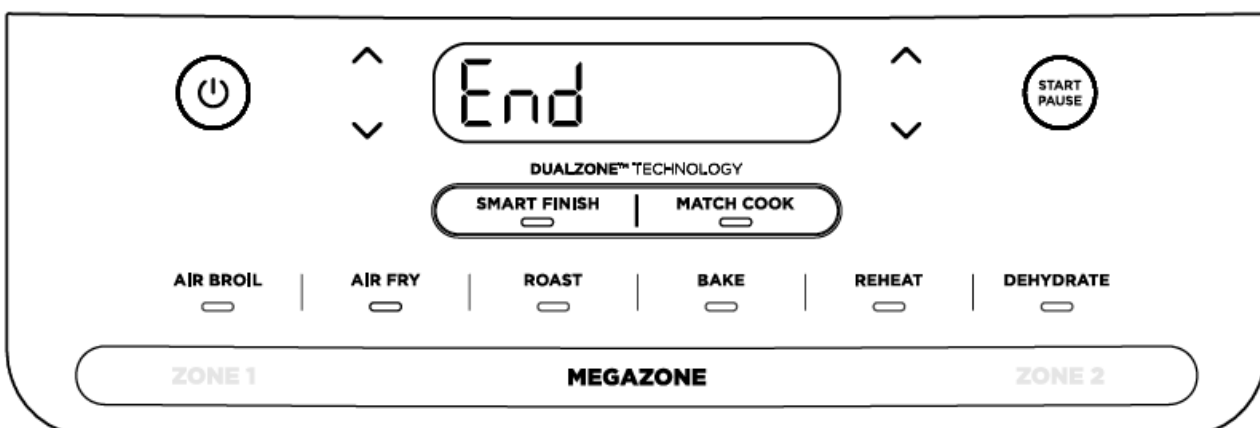

6. Remove ingredients by dumping them out or using silicone-tipped tongs/utensils.

Air Fry

1. Remove the divider from the basket, then insert both crisper plates in the basket. Place ingredients in the basket, then insert the basket into the unit.

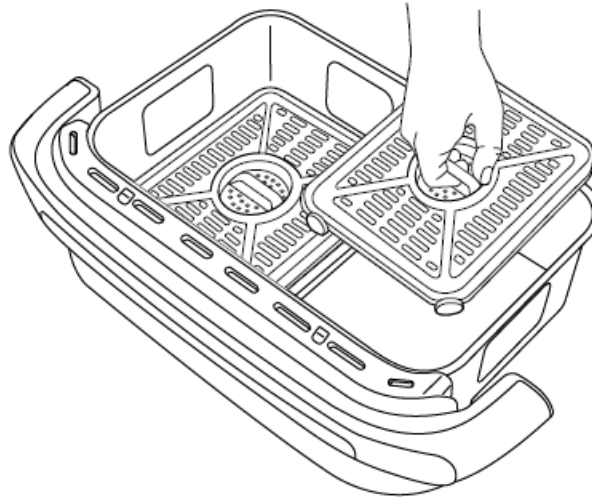

2. The unit will default to Zone 1. Select MEGAZONE, then select AIR FRY.

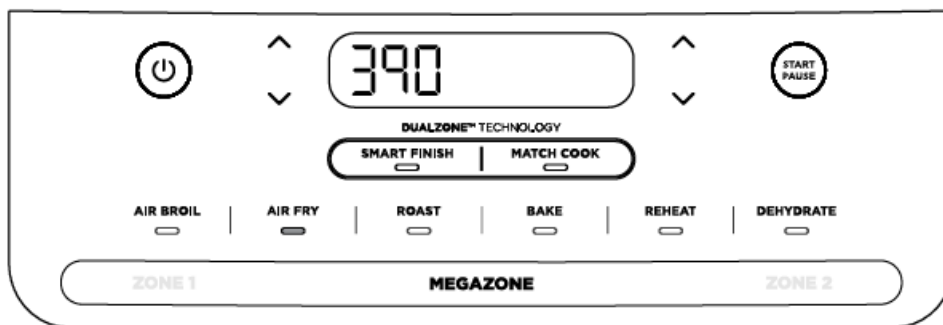

3. Use the TEMP arrows to set the desired temperature.



4. Use the TIME arrows to set the time in 1-minute increments up to 1 hour. Press START/PAUSE to begin cooking.

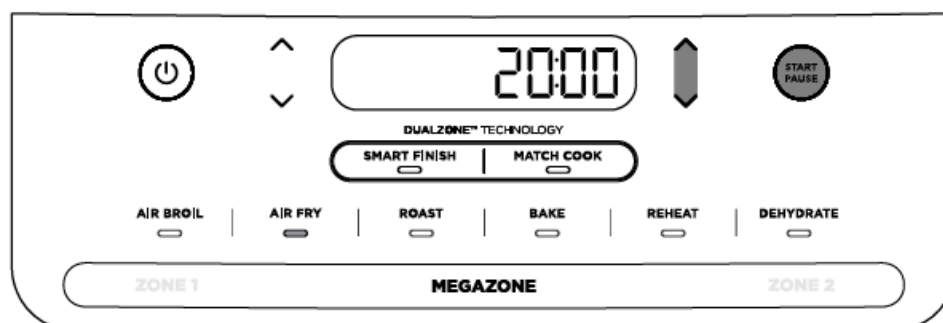

- **NOTE:** During cooking, you can remove the basket and shake or toss ingredients for evening crisping. If you would like to pause cooking during this time, press START/PAUSE.

5. When cooking is complete, the unit will beep and “End” will appear on the display.

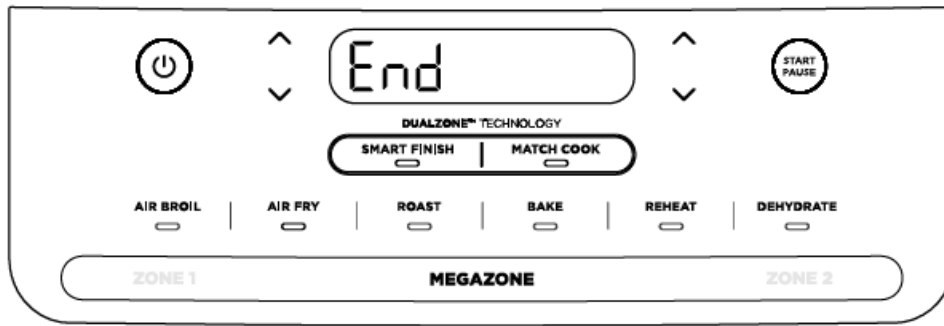

6. Remove ingredients by dumping them out or using silicone-tipped tongs/utensils.

Roast

1. Remove the divider from the basket, then insert both crisper plates in the basket. Place ingredients in the basket, then insert the basket into the unit.

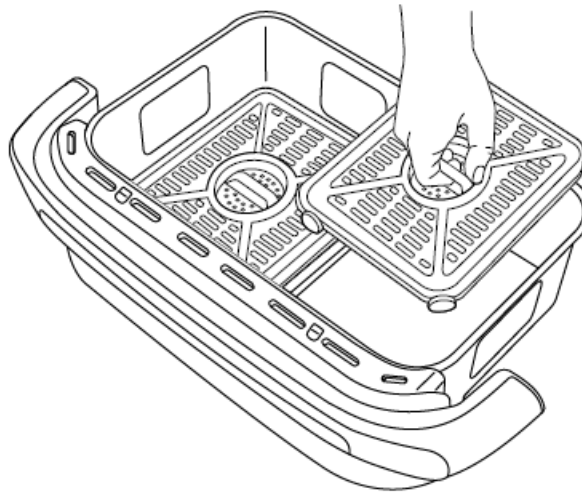

2. The unit will default to Zone 1. Select MEGAZONE, then select ROAST.

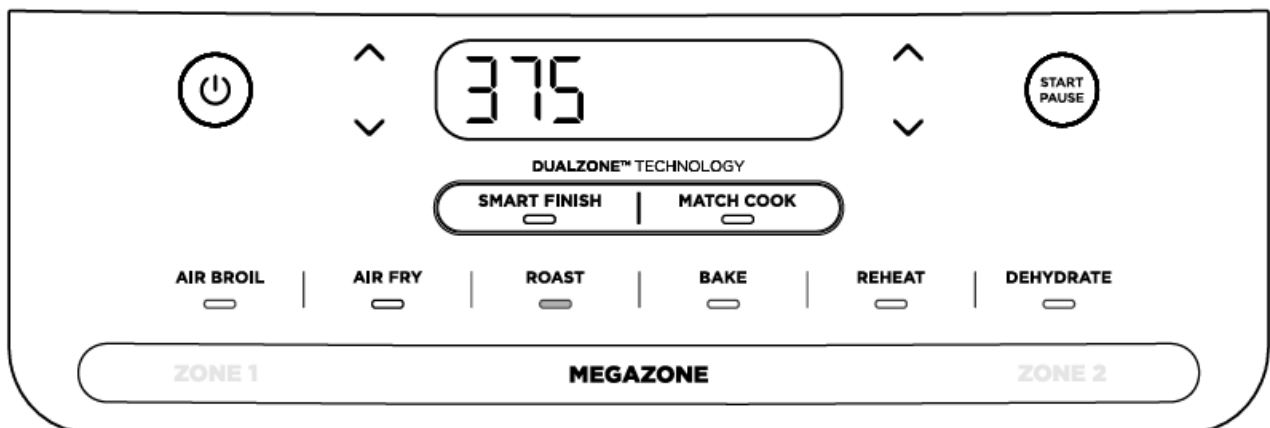

3. Use the TEMP arrows to set the desired temperature.

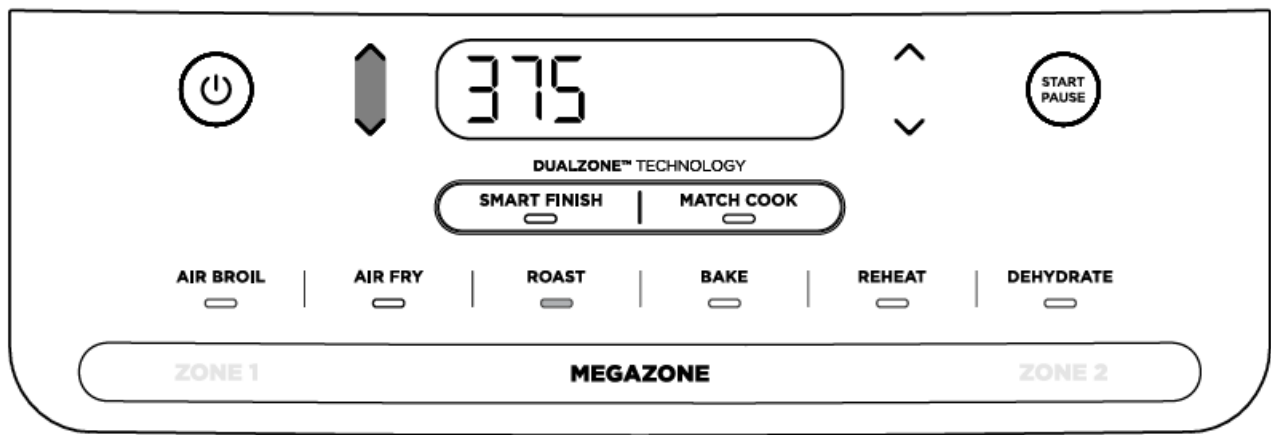

4. Use the TIME arrows to set the time in 1-minute increments up to 1 hour and in 5-minute increments from 1 to 4 hours. Press START/PAUSE to begin cooking.

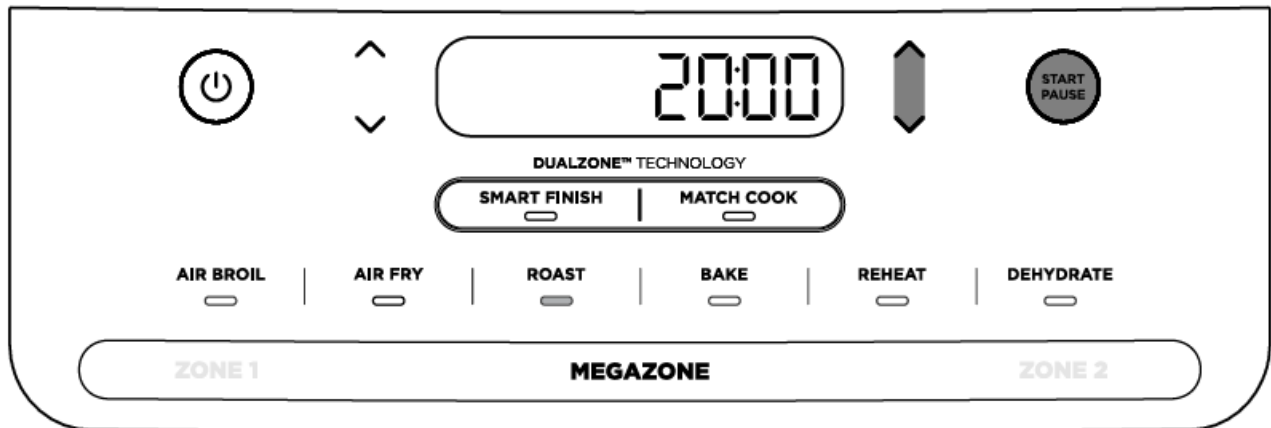

5. When cooking is complete, the unit will beep and “End” will appear on the display.

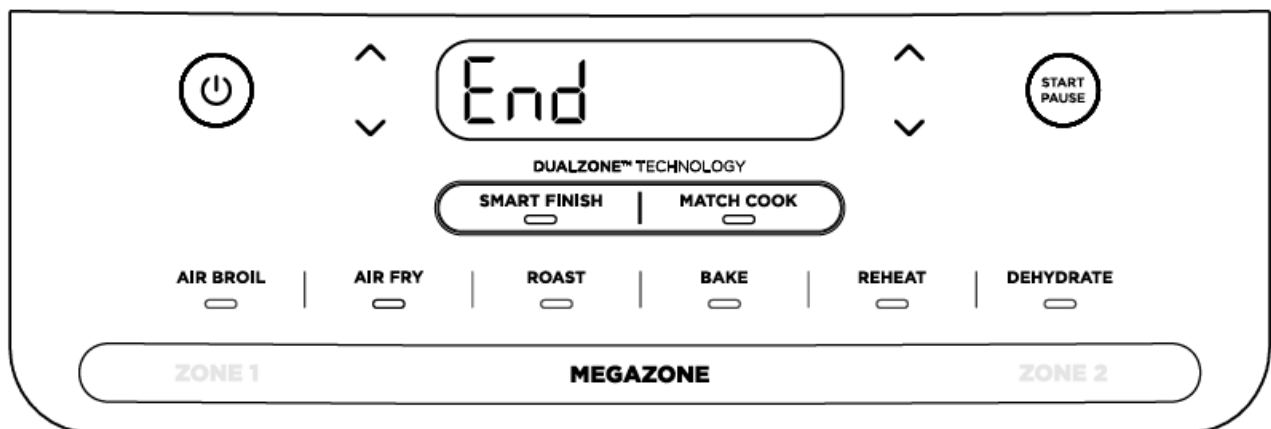

6. Remove ingredients by dumping them out or using silicone-tipped tongs/utensils.

Bake (Not available on all models.)

1. Remove the divider from the basket, then insert both crisper plates in the basket. Place ingredients in the basket, then insert the basket into the unit.

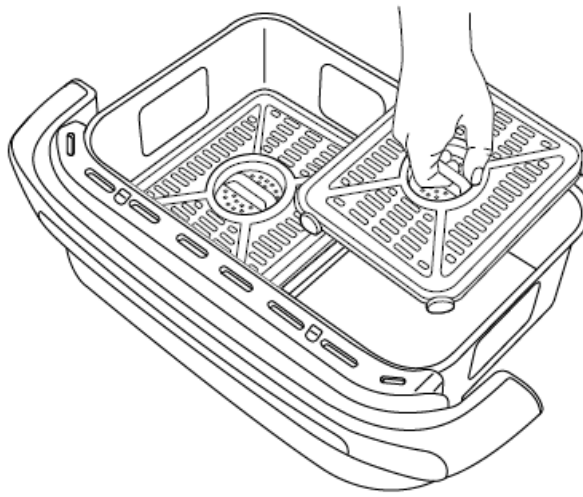

2. The unit will default to Zone 1. Select MEGAZONE, then select BAKE.



- **NOTE:** To convert recipes from a traditional oven, reduce the temperature by 25°F.

3. Use the TEMP arrows to set the desired temperature.



4. Use the TIME arrows to set the time in 1-minute increments up to 1 hour and in 5-minute increments from 1 to 4 hours. Press START/PAUSE to begin cooking.

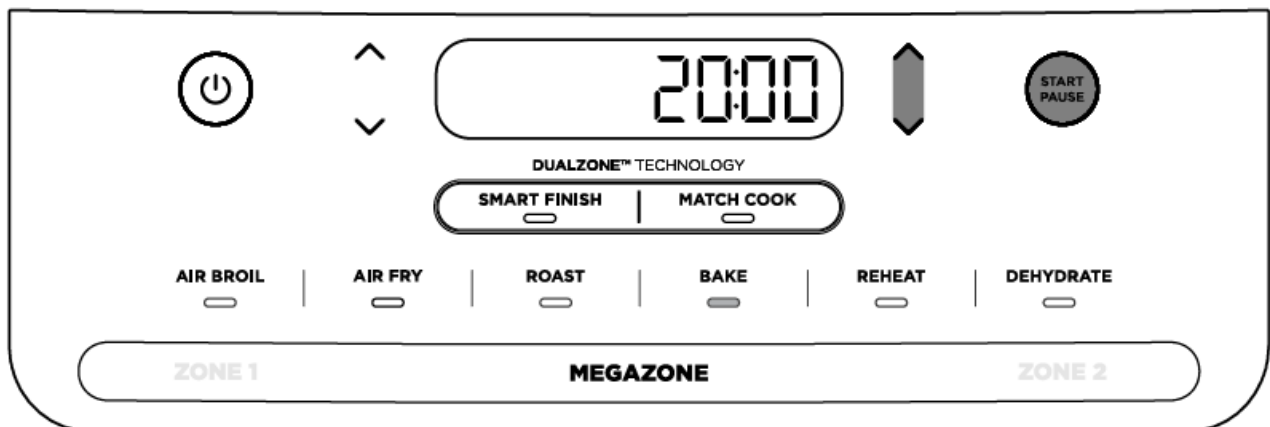

5. When cooking is complete, the unit will beep and “End” will appear on the display.

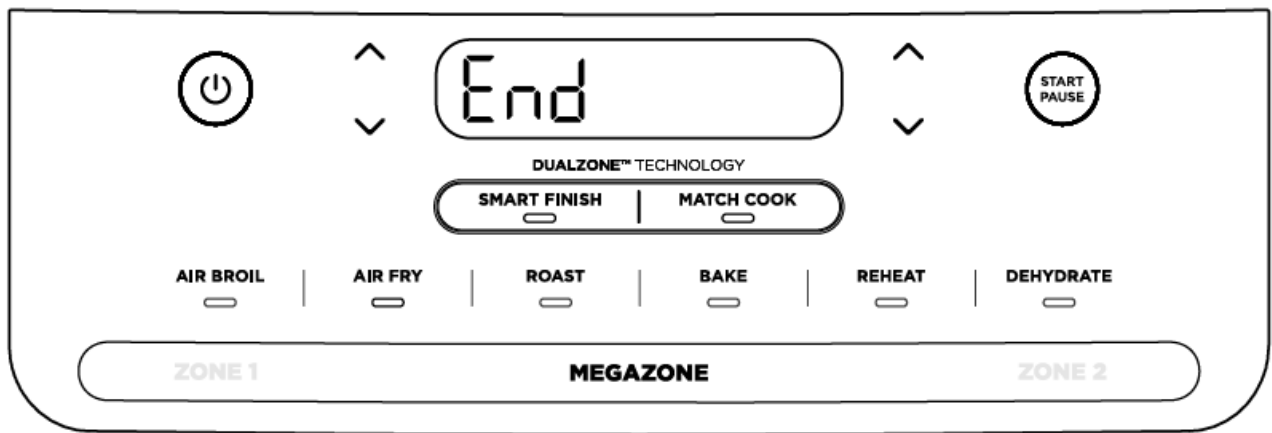

6. Remove ingredients by dumping them out or using silicone-tipped tongs/utensils.

Reheat

1. Remove the divider from the basket, then insert both crisper plates in the basket. Place ingredients in the basket, then insert the basket into the unit.

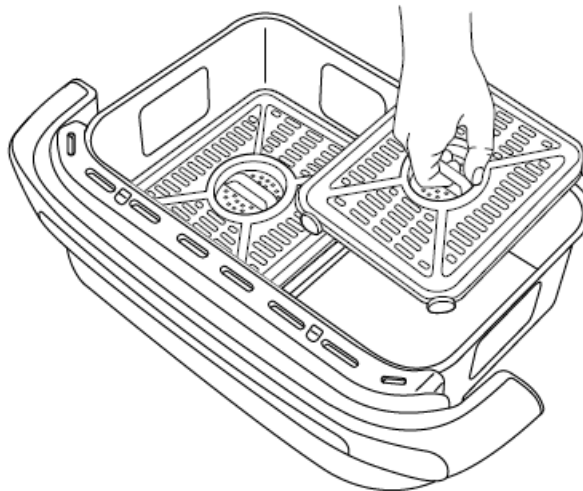

2. The unit will default to Zone 1. Select MEGAZONE, then select REHEAT.

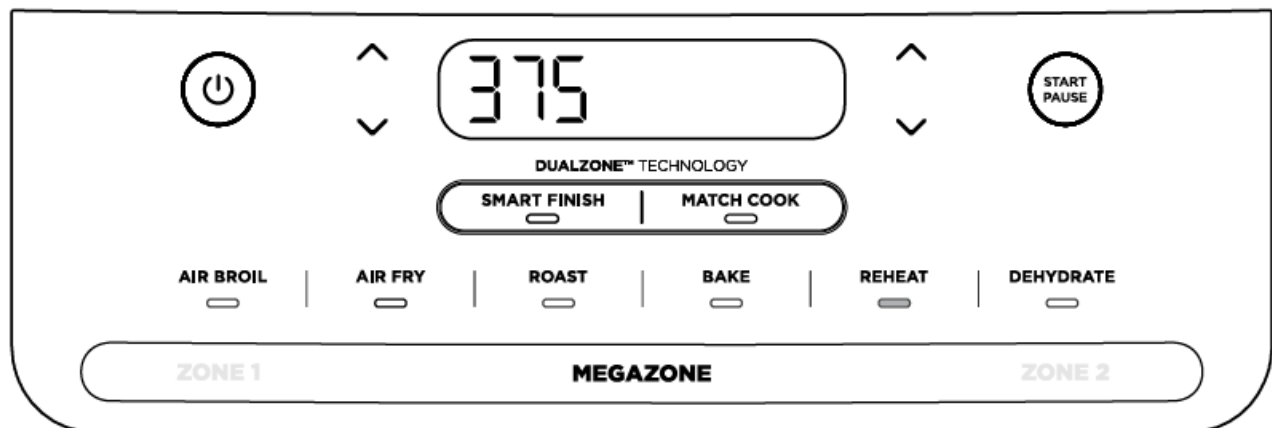

3. Use the TEMP arrows to set the desired temperature.



- Use the TIME arrows to set the time in 1-minute increments up to 1 hour. Press START/PAUSE to begin cooking.



- When cooking is complete, the unit will beep and “End” will appear on the display.

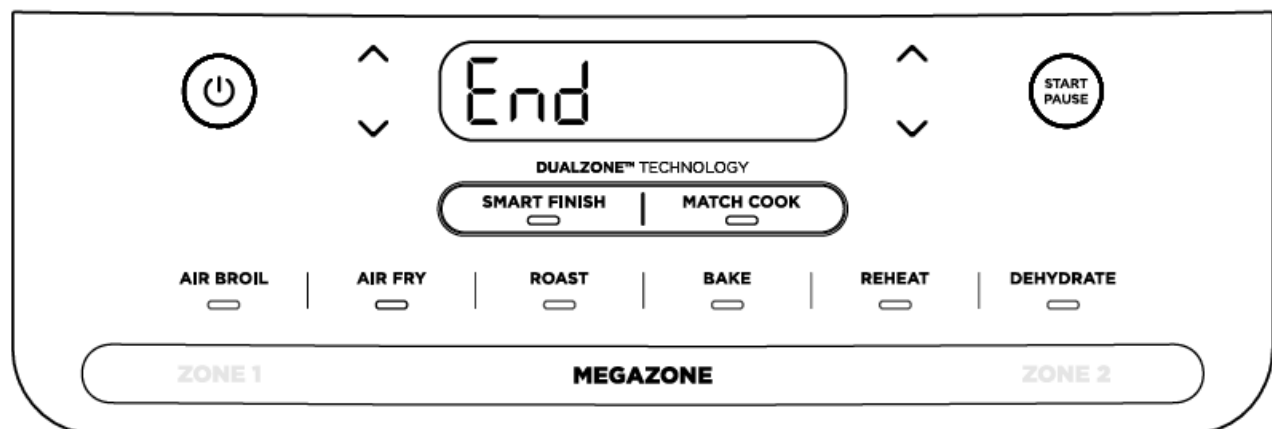

- Remove ingredients by dumping them out or using silicone-tipped tongs/utensils.

Dehydrate

- Remove the divider from the basket, then insert both crisper plates in the basket. Place ingredients in the basket, then insert the basket into the unit.

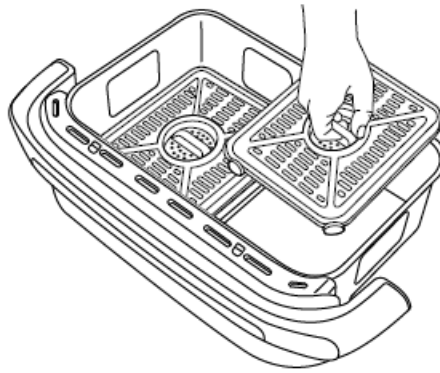

2. The unit will default to Zone 1. Select MEGAZONE, then select DEHYDRATE.

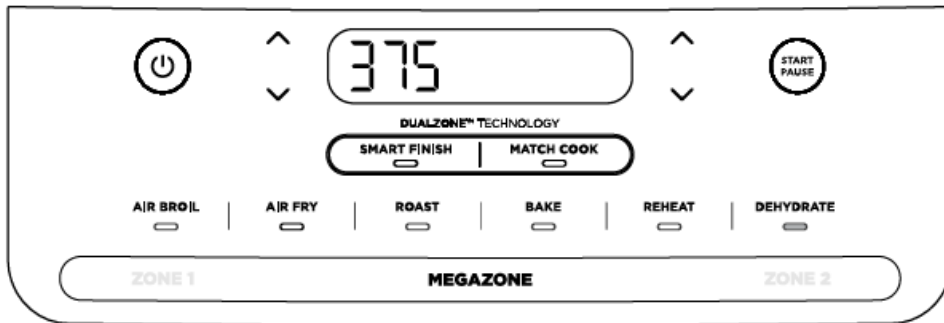

3. Use the TEMP arrows to set the desired temperature.

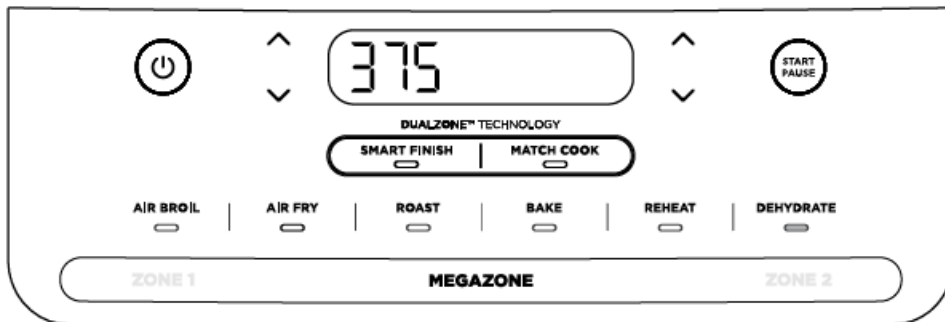

4. Use the TIME arrows to set the time in 15-minute increments from 6 to 12 hours. Press START/PAUSE to begin cooking.

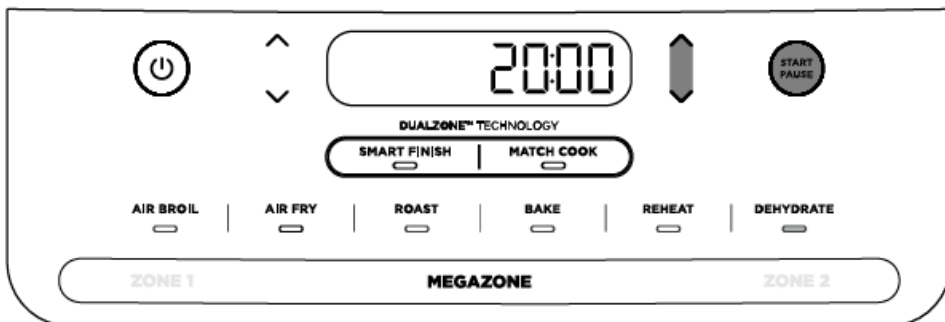

5. When cooking is complete, the unit will beep and “End” will appear on the display.

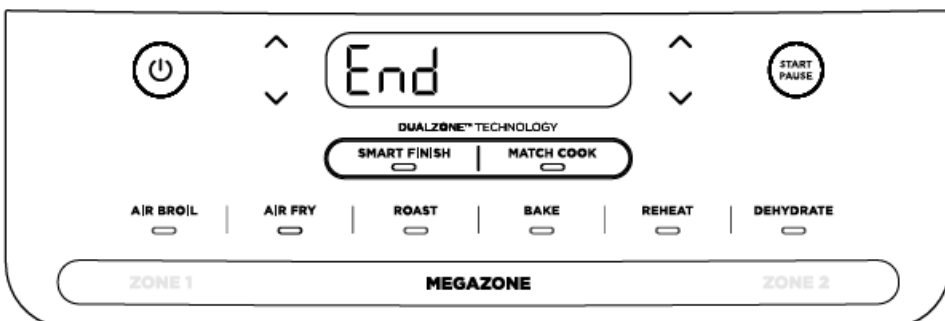

6. Remove ingredients by dumping them out or using silicone-tipped tongs/utensils.

CLEANING YOUR FLEXBASKET™ AIR FRYER

The unit should be cleaned thoroughly after every use. Unplug the unit from the wall outlet before cleaning.

Part/Accessory	Cleaning Method	Dishwasher Safe?
Main Unit	To clean the main unit and the control panel, wipe them clean with a damp cloth. NOTE: NEVER immerse the main unit in water or any other liquid. NEVER clean the main unit in a dishwasher.	No
Crisper Plates	The crisper plates can be washed in the dishwasher or by hand. If hand-washing, air-dry or towel-dry all parts after cleaning.	Yes
Basket	The basket can be washed in the dishwasher or by hand. If hand-washing, air-dry or towel-dry all parts after cleaning. *To extend the life of your basket, we recommend hand-washing them.	Yes*
Divider	The divider can be washed in the dishwasher or by hand. If hand-washing, air-dry or towel-dry all parts after cleaning.	Yes

If food residue is stuck on the crisper plates or basket, place them in a sink filled with warm, soapy water and allow to soak.

HELPFUL TIPS

1. For consistent browning, make sure ingredients are arranged in an even layer on the bottom of the basket with no overlapping. If ingredients are overlapping, make sure to shake them halfway through cooking.
2. Cook temperature and time can be adjusted at any time during cooking. Simply select the zone you want to adjust, then press the TEMP arrows to adjust the temperature or the TIME arrows to adjust the time.
3. To convert recipes from a traditional oven, reduce the temperature by 25°F. Check food frequently to avoid overcooking.
4. Occasionally, the fan from the air fryer will blow lightweight foods around. To alleviate this, secure foods (like the top slice of bread on a sandwich) with wooden toothpicks.
5. The crisper plates elevate ingredients in the basket so air can circulate under and around ingredients for even, crisp results.
6. After selecting a cook function, you can press START/PAUSE to begin cooking immediately. The unit will run at the default temperature and time.
7. For best results with fresh vegetables and potatoes, use at least 1 tablespoon of oil. Add more oil as desired to achieve the preferred level of crispiness.
8. For best results, check progress throughout cooking and remove food when the desired level of brownness has been achieved. We recommend using an instant-read thermometer to monitor the internal temperature of proteins.
9. For best results, remove food directly after the cooking time ends to avoid overcooking.

TROUBLESHOOTING GUIDE

• How do I adjust the temperature or time while using a single zone?

- When a single zone is running the time or temperature can be adjusted at any time by pressing the up/down arrows.

• How do I adjust the temperature or time while using both zones?

- Select the desired zone, then use the TEMP arrows to adjust the temperature or the TIME arrows to

adjust the time.

- **Can I cook different foods in each zone and not worry about cross-contamination?**
 - Yes, both zones are self-contained with separate heating elements and fans.
- **How do I pause or stop one zone when using both zones?**
 - Select the zone you want to pause or stop, then press START/PAUSE.
- **Is the basket safe to put on my countertop?**
 - The basket will heat up during cooking. Use caution when handling them, and place them on heat-safe surfaces only. DO NOT place the basket on the top of the unit.
- **When should I use the crisper plate?**
 - Use the crisper plate when you want food to come out crispy. The plate elevates the food in the basket so that air can flow under and around it to cook ingredients evenly.
- **Why didn't my food cook fully?**
 - Make sure the basket is fully inserted during cooking.
 - For consistent browning, make sure ingredients are arranged in an even layer on the bottom of the basket with no overlapping.
 - Shake the basket to toss ingredients for even crispiness. Cook temperature and time can be adjusted at any time during cooking. Simply use the TEMP arrows to adjust the temperature or the TIME arrows to adjust the time.
- **Why is my food burned?**
 - For best results, check progress throughout cooking and remove food when the desired level of brownness has been achieved. Remove food immediately after the cooking time ends to avoid overcooking.
- **Why do some ingredients blow around when air frying?**
 - Occasionally, the fan from the air fryer will blow lightweight foods around. Use wooden toothpicks to secure loose lightweight food, like the top slice of bread on a sandwich.
- **Can I air-fry wet, battered ingredients?**
 - Yes, but use the proper breading technique. It is important to coat foods first with flour, then with egg, and then with bread crumbs. Press breading firmly onto the battered ingredients, so crumbs won't be blown off by the fan.
- **Why did the display screen go black?**
 - The unit is in standby mode. Press the power  button to turn it back on.
- **Why is the unit beeping?**
 - Either the food is done cooking, or the other zone has started cooking.
- **Why is there an "E" message on the display screen?**
 - The unit is not functioning properly. Please contact Customer Service at 1-877-646-5288.
- **Why did a circuit breaker trip while using the unit?**
 - The unit uses 1690 watts of power, so it must be plugged into an outlet on a 15-amp circuit breaker.
 - Using an outlet on a 10-amp breaker will cause the breaker to trip. It is also important that the unit be the only appliance plugged into an outlet when in use.
 - To avoid tripping a breaker, make sure the unit is the only appliance plugged into an outlet on a 15-amp breaker.

WARRANTY

ONE (1) YEAR LIMITED WARRANTY

The One (1) Year Limited Warranty applies to purchases made from authorized retailers of SharkNinja Operating LLC. Warranty coverage applies to the original owner and to the original product only and is not transferable. SharkNinja warrants that the unit shall be free from defects in material and workmanship for one (1) year from the date of purchase when it is used under normal household conditions and maintained according to the requirements outlined in the Owner's Guide, subject to the following conditions and exclusions:

What is covered by this warranty?

1. The original unit and/or non-wearable parts deemed defective, in SharkNinja's sole discretion, will be repaired or replaced up to one (1) year from the original purchase date.
2. In the event a replacement unit is issued, the warranty coverage ends six (6) months following the receipt date of the replacement unit or the remainder of the existing warranty, whichever is later. SharkNinja reserves the right to replace the unit with one of equal or greater value.

What is not covered by this warranty?

1. Normal wear and tear of wearable parts (such as blending vessels, lids, cups, blades, blender bases, removable pots, racks, pans, etc.), which require regular maintenance and/or replacement to ensure the proper functioning of your unit, are not covered by this warranty. Replacement parts are available for purchase at ninjaaccessories.com.
2. Any unit that has been tampered with or used for commercial purposes.
3. Damage caused by misuse, abuse, negligent handling, failure to perform required maintenance (e.g., failure to keep the well of the motor base clear of food spills and other debris), or damage due to mishandling in transit.
4. Consequential and incidental damages.
5. Defects caused by repair persons not authorized by SharkNinja. These defects include damages caused in the process of shipping, altering, or repairing the SharkNinja product (or any of its parts) when the repair is performed by a repair person not authorized by SharkNinja.
6. Products purchased, used, or operated outside North America.

How to get service

- If your appliance fails to operate properly while in use under normal household conditions within the warranty period, visit ninjakitchen.com/support for product care and maintenance self-help.
- Our Customer Service Specialists are also available at 1-877-646-5288 to assist with product support and warranty service options, including the possibility of upgrading to our VIP warranty service options for select product categories.
- So we may better assist you, please register your product online at registeryourninja.com and have the product on hand when you call.
- SharkNinja will cover the cost for the customer to send in the unit to us for repair or replacement.
- A fee of \$20.95 (subject to change) will be charged when SharkNinja ships the repaired or replacement unit.

How to initiate a warranty claim

- You must call 1-877-646-5288 to initiate a warranty claim.

- You will need the receipt as proof of purchase.
- We also ask that you register your product online at registeryourninja.com and have the product on hand when you call, so we may better assist you.
- A Customer Service Specialist will provide you with return and packing instruction information.

How state law applies

- This warranty gives you specific legal rights, and you also may have other rights that vary from state to state.
- Some states do not permit the exclusion or limitation of incidental or consequential damages, so the above may not apply to you.

ninjakitchen.com.

Documents / Resources

	<p>NINJA DZ071 Dual Zone Flex Basket Air Fryer [pdf] Instruction Manual DZ071 Dual Zone Flex Basket Air Fryer, DZ071, Dual Zone Flex Basket Air Fryer, Zone Flex Basket Air Fryer, Flex Basket Air Fryer, Basket Air Fryer</p>
--	--

References

- [🔍 Find Replacement Parts & Accessories](#)
- [🍳 Ninja® Kitchen Appliances | Air Fryers, Blenders, Grills & More](#)
- [🇬🇧 Ninja United Kingdom](#)
- [User Manual](#)

[Manuals+](#), [Privacy Policy](#)

This website is an independent publication and is neither affiliated with nor endorsed by any of the trademark owners. The "Bluetooth®" word mark and logos are registered trademarks owned by Bluetooth SIG, Inc. The "Wi-Fi®" word mark and logos are registered trademarks owned by the Wi-Fi Alliance. Any use of these marks on this website does not imply any affiliation with or endorsement.